

Where are you?

Materials for Observing and Experimenting

Experiments with:

- The Globe
- The Compass
- The Sundial
- The Protractor
- The Quadrant
- The Nocturnal



AGÊNCIA NACIONAL
PARA A CULTURA
CIENTÍFICA E TECNOLÓGICA

This booklet describes several experiments and observation activities aimed at children aged eight and over. The activities may be used as a stimulus to observation by parents or by teachers in Basic Education.

The booklet comes with a compass and five cut-outs to make a globe, a sun dial, a protractor, a quadrant and a nocturnal.

Building and using these instruments act as a stimulus to observe the world around us.

The booklet is completed by the *Latitude and Longitude* text.

Ciência Viva would like to thank Professor Rui Dilão for his ideas from project conception to final product and Professor Maurice Bazin and Dr. Elisa Figueira for unwavering support throughout the different stages of the project.

Editorial Staff

Text and Instruments: Rui Dilão

Revision and Suggestions: Maurice Bazin, Elisa Figueira, Helena Fonseca, Carlos Rodrigues and the *Ciência Viva* team.

Comments on the text: Ana Teodoro, Dulce Marcelino, Suzana Andrade and Maria João Mora.

Graphic Design: FPGBdesign

Internet Edition: Simbiose

Pilot testing in schools: E. S. Luísa de Gusmão (Lisboa), E. S. Rainha D. Amélia (Lisboa), E. S. José Régio (Vila do Conde) and EB2,3 D. Manuel I (Alcochete) and Colégio de Quaiaios. Our thanks to the teachers and students who took part in these tests.

Acknowledgements: The view of the Earth and the Sun on Pages 2 and 5 courtesy of the NASA Photo Bank. The astrolabe diagram courtesy of the Naval Museum. Some of the Earth pictures are from John Walker's web page. The globe was designed from data 88-MGG-02, *Digital Relief of the Surface of the Earth*, NOAA, National Geographic Data Center, Boulder, Colorado, 1988. Our thanks to all.

Printers: Eurodois

Print run: 1.000

Depósito legal: 135928/02

ISBN: 972-97805-7-9

© *Ciência Viva* - Agência Nacional para a Cultura Científica e Tecnológica, 2002

<http://www.cienciaviva.pt>



Materials for observing and experimenting

The Globe



The protractor

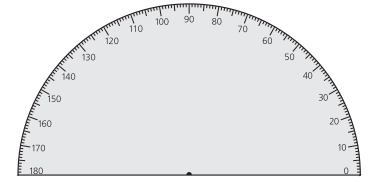

The compass



The astrolabe and the quadrant



The sundial

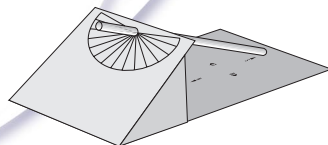

The nocturnal

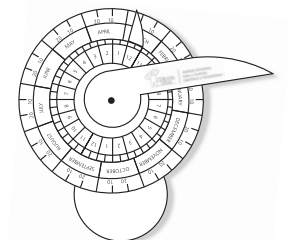

The Globe

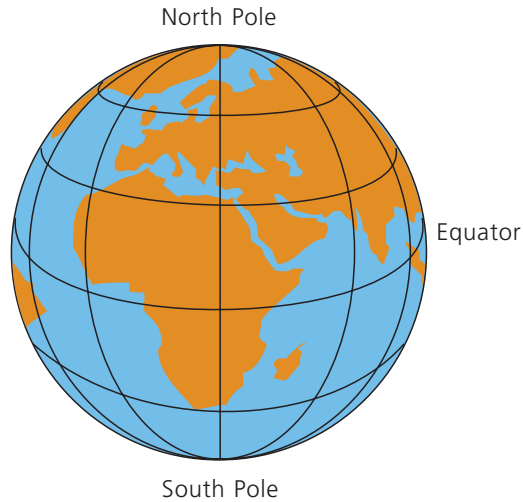

The Earth as shown on your globe.



The Earth as seen from space. Besides the continents and the oceans, some clouds are also visible.

Activity

- Cut out and make the globe. Find the Northern Hemisphere, the Southern Hemisphere and the Equator.
- In the picture of the Earth from space, can you point out the ice packs of the South Pole?

The Earth is in the shape of a ball. There are two very cold areas covered in ice, which man calls the North Pole and the South Pole. The Northern Hemisphere is made up of regions which are closer to the North Pole than to the South Pole. The Southern Hemisphere is made up of regions which are closer to the South Pole than to the North Pole. The region of the Earth which is the same distance from both poles is called the Equator.

The Earth is made up of oceans and continents.
Man gave names to the oceans and the continents.

America or the American continent is so big that it was divided into three regions: North America, Central America and South America.

Activity

- On your globe, find the following oceans: the Atlantic Ocean, the Indian Ocean, the Pacific Ocean and the Arctic Ocean.
- On your globe, find the following continents: Africa, America, Asia and Europe, Antarctica and Australia.
- On your globe, find the place where you live.

The Arctic Ocean is so cold that the surface of the sea is frozen and you can walk across it. But a submarine can pass below the layer of ice on the surface, because the sea does not freeze underneath. It is in the polar regions that icebergs form and expand deep into the sea. People who live near the North Pole have no night during the summer, and no day during the winter.

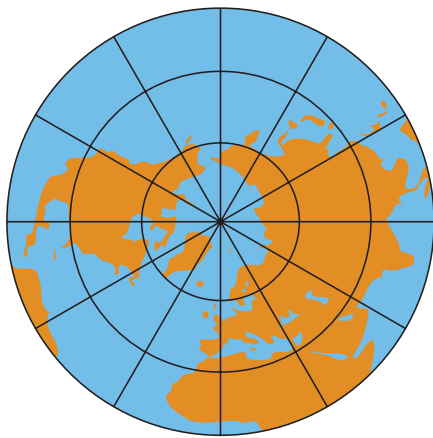

The Northern Hemisphere

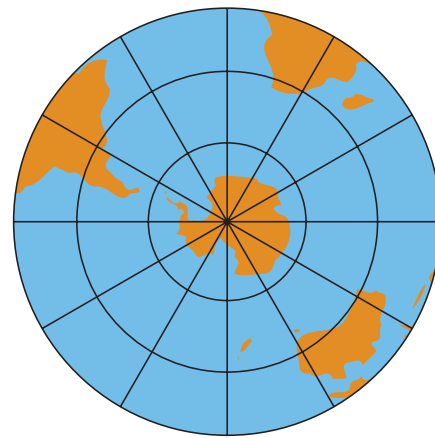

The Southern Hemisphere

The Compass

The compass is an instrument that points to the Earth's North Pole. On Earth we can use a compass to guide us because the needle points to the approximate position of the North Pole.

The compass face also shows the South Pole, which is in the opposite direction to North, as well as the position of the Sun at sunrise and sunset. The Sun rises in the East and sets in the West.



The compass rose and the cardinal points

The four directions north (N), south (S), East (E) and west (W) are the cardinal points of the compass rose.

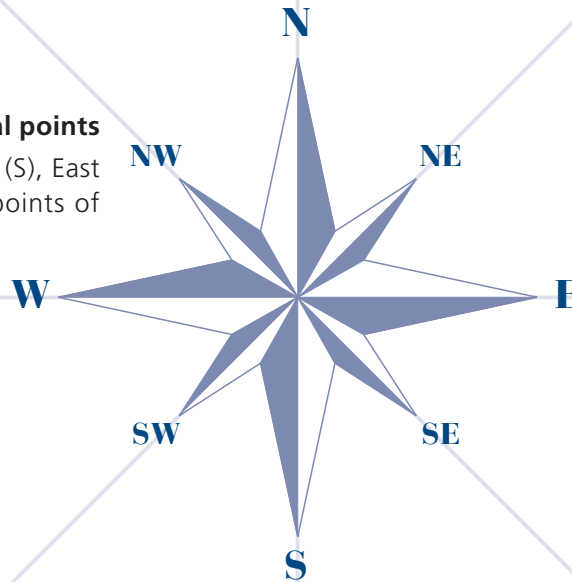

Observation

- Take your compass and place it on your hand. Wait until the needle stops moving and then turn to the north. If you live in Portugal and it is daytime, the Sun is almost always behind you. Can you say on which side the sun rises and sets?

Experiment

- Place your compass near a magnet, for instance, very close to the rubber on a fridge door. (The rubber on the door contains a magnet!) What happens?
- Try changing the position of the magnet. What happens to the needle of the compass? Why does your compass always point north?

It is because inside the Earth there is a metal - iron, which acts like a giant compass running from north to south!

The sundial

The Sun is a star, a very hot ball of gas which gives us the heat and light that are necessary for life.

As you can see, the Sun is a huge ball of fire that lights and heats the Earth.

In summer, the Sun climbs higher in the sky and the days are longer than the nights. During winter, the Sun does not climb so high and there are less hours of sunlight so this is why it is colder.

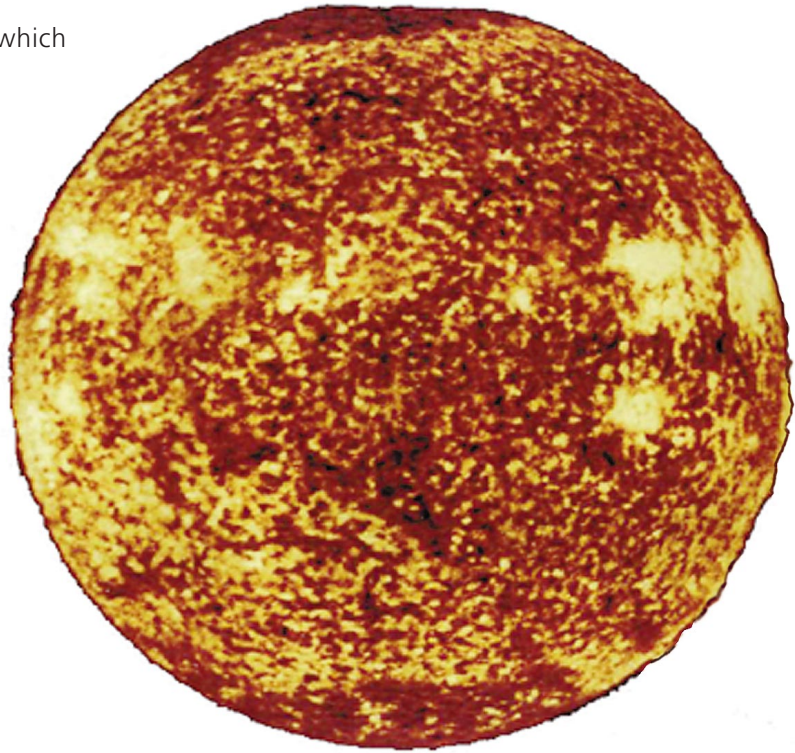

Observation

- When the Sun is at its highest in the sky, it is the middle of the day. You can find out when it is midday by looking at shadows. Look at the shadows of trees or buildings when you are going to school in the morning; the shadows are longer in the morning; shorter at midday and longer again in the afternoon.

Experiment

- On your own or with your friends make a mark on the ground in a large area. Make sure that you are allowed to do this. The ideal place would be the school yard. Stand on the mark and ask a friend to mark the end of your shadow in chalk. Repeat this several times during the day. The length of your shadow will vary throughout the day. It will be shorter at midday and longer at the beginning and end of the day.
- Draw a straight line through the different points that you marked in chalk. Stand on the central mark again and turn towards the closest mark on this line. You have just turned to face the Earth's North Pole. Check it with your compass. Now draw the compass rose and the cardinal points on the ground.

Experiment

The Sun is at its highest in the sky at midday. At sunrise and sunset your shadow is longer. Now you can make a clock which will tell you what time of day it is.

- Cut out your sundial from the card and fold it as shown in the diagram.
- Cut out a U-shape along the top and sides of the rectangle and fold it along the dotted line.
- Cut out the black dot of the clock face so that you can fit a straw through it.
- Glue the grey flaps of the card to the bottom of the sundial and push the straw through the hole.
- Slope the straw so that the bottom fits around the raised piece of card that you cut out.

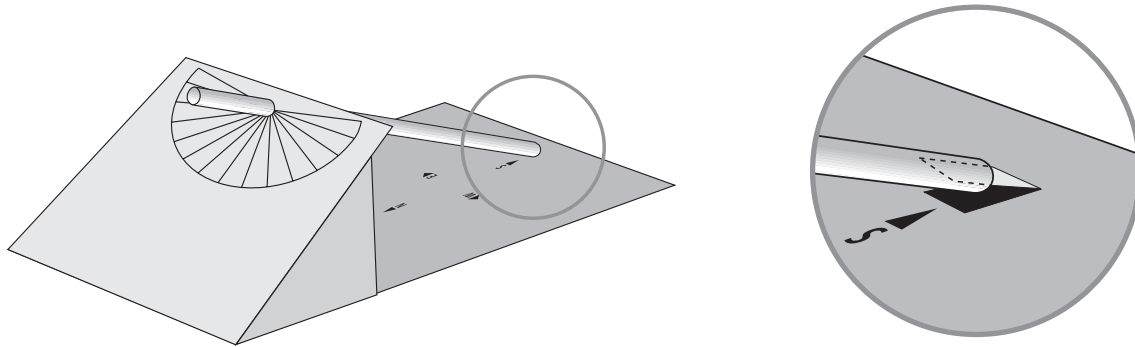

- Place your sundial in a sunlit spot in the fresh air, on the window or on the balcony.
- Using your compass, line up your sundial with the cardinal points marked on the card.

Your sundial is now working. The shadow of the straw shows approximate noon time on the clock face.

In spring and summer the shadow of the straw falls on the outer face, in autumn and winter the shadow falls on the inner face.

If you place your sundial on the window you will always know whether it is morning or afternoon or whether it is midday. With a little practice you will also know whether it is spring-summer or autumn-winter.

Note that in summer, sunrise occurs before six o'clock solar time and that sunset is also later. In winter, it is exactly the opposite. This is because in summer the days are longer than the nights and in winter the nights are longer than the days.

Measuring angles and widths

An angle is the measurement of one full line of a circumference.

For example, if you trace a full line along the surface of an orange or a ball with your finger, when you arrive at the point you started from you have gone a 360° angle. In other words, you circled an angle of 360° on the ball or the orange.

Experiment

- Cut out the protractor. A protractor is a special ruler which is used to measure angles on a circumference.
- You can now use your protractor to trace a semi-circumference and measure the angles when you follow the circumference from the right-hand side. The black dot on the protractor is the centre of the circumference.

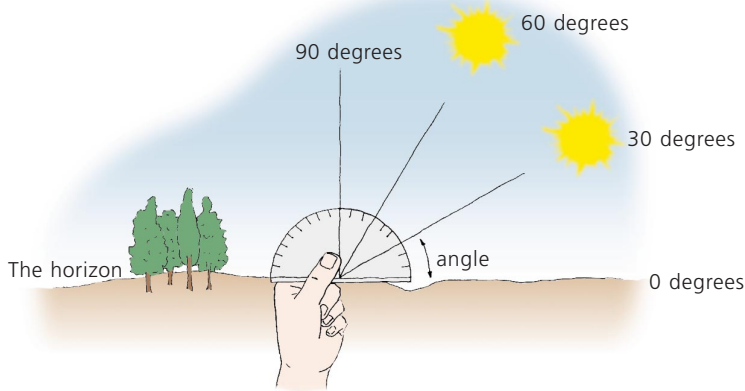

The diagram shows angles of 0 degrees, 30 degrees, 60 degrees and 90 degrees.

Semi-circumference corresponds to a 180° angle and a full circumference corresponds to 360° degrees. When the Sun is at its highest in the sky its angle above the horizon line is larger. At sunrise and sunset, it is closer to the horizon and its angle is much smaller. The 0 degree angle is the horizon line.

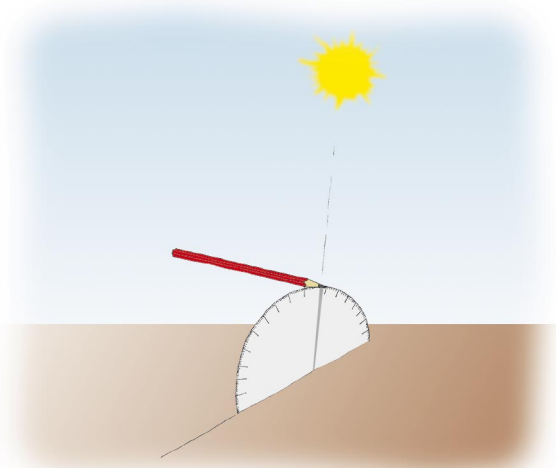

- Get your protractor and a pencil.
- Line up your protractor with the Sun so that the shadow of the protractor is as thin as possible. Put the point of the pencil on top of the protractor in such a way that its shadow falls through the black dot on the protractor. The point of the pencil shows a number on the scale. This is the angle of the Sun above the horizon.

The Astrolabe and the Quadrant

An astrolabe is an instrument used to measure angles.

About 500 years ago, Portuguese navigators who discovered the islands of the Azores, Cape Verde and Brazil used the astrolabe so that they would not get lost at sea. Using the astrolabe they were able to calculate their position on earth by measuring the angle of the Sun above the horizon.



The Astrolabe that the Portuguese navigators used on board ship to calculate the height of the Sun throughout the day.

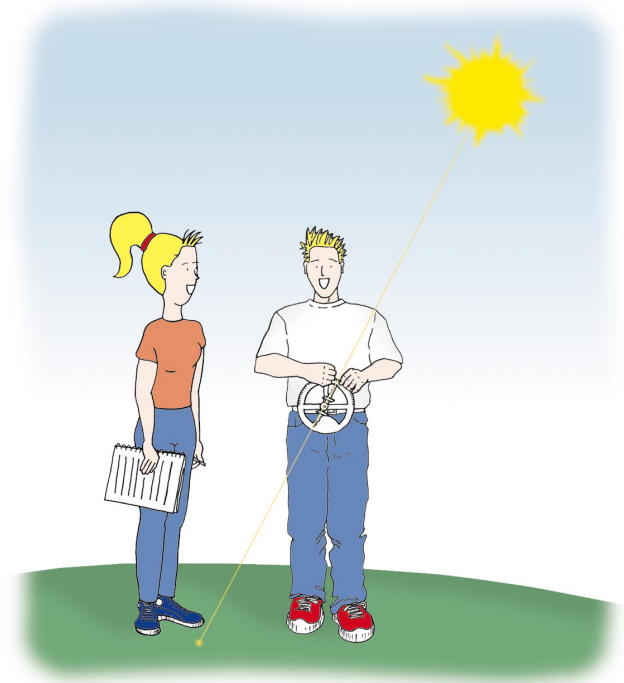

Using the astrolabe to measure the angle of the Sun above the horizon.

You can find out the height of your house, your school or trees in a park with the aid of an astrolabe. This can also be done with a quadrant, which is like the fourth part of an astrolabe.

Experiment

- Cut out the card quadrant and the four black dots on the flaps.
- Fold the flaps over and insert a straw through the holes.
- Use a needle to put a thread through the hole on the quadrant. Tie the two ends so that the quadrant hangs on the loop.
- Tie a weight onto the thread so that it hangs down.

Your quadrant should look like this:

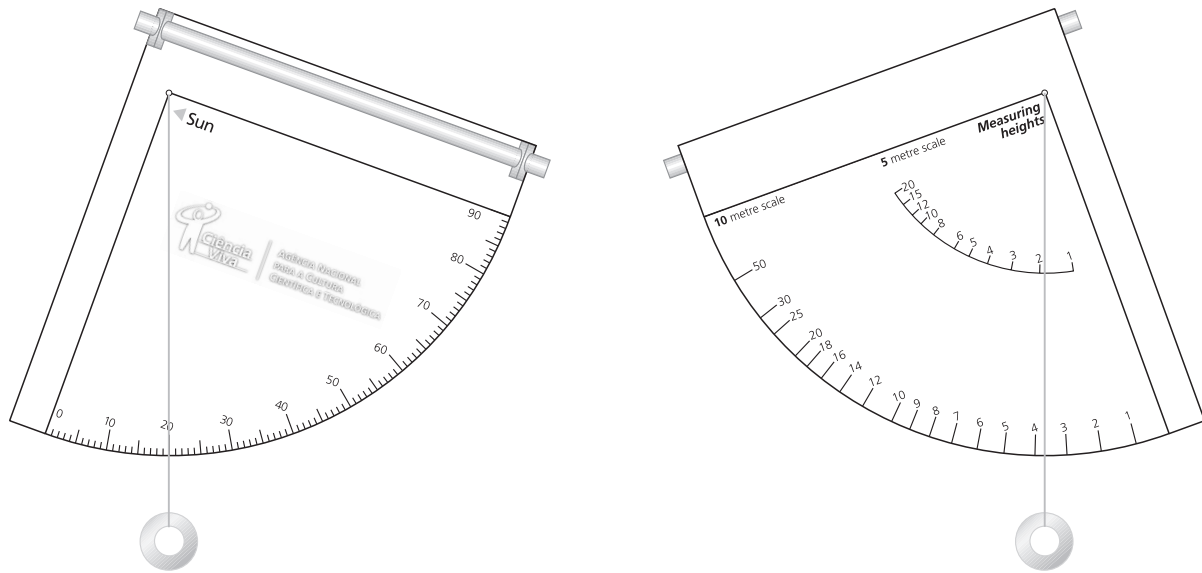

Be very careful when you are using your quadrant - you should never look at the Sun through the straw because you could damage your eyes.

- Now you can use your quadrant to measure the angle of the Sun above the horizon. Hold your quadrant in one hand and turn the straw towards the Sun. Put your other hand on the outer end of the straw and tilt the quadrant until you can see a bright spot on the palm of your hand. Read the number where the thread lies and you will find out the angle of the Sun above the horizon. Early in the morning this angle is smaller and at midday it is larger. If you do the experiment with your protractor, you will see that the measurements given by both the quadrant and the protractor are the same.

We can also use the quadrant to measure the height of a tree in a park.

On one side of your quadrant, there is a scale in degrees just like the protractor. This scale measures a deviation or an angle above the horizon. On the other side, the scale gives you the height of an object.

To find out the height of a tree, follow these instructions:

- Choose the tree you want to measure. Stand five metres - five large steps - away from it in a straight line in any direction and then turn to face the tree.
- Hold up your quadrant and look at the top of the tree through the straw. The thread shows a number on the five metre scale on the quadrant. This figure is the height of the tree from your eye level.
- To find out the height of the tree, measure the distance from your eyes to the ground and add this to the number you read on the quadrant. E.g. if you read 3.5m on the quadrant and you are 1.20m tall, the height of the tree is $3.5 + 1.20 = 4.70\text{m}$.
On the other side of the quadrant, you can see the angle from which you are looking at the tree. The higher the tree, the greater the angle.
- You can repeat this experiment with higher houses from a distance of 10 metres. In this case you must use the ten metre scale on your quadrant to find out the height.

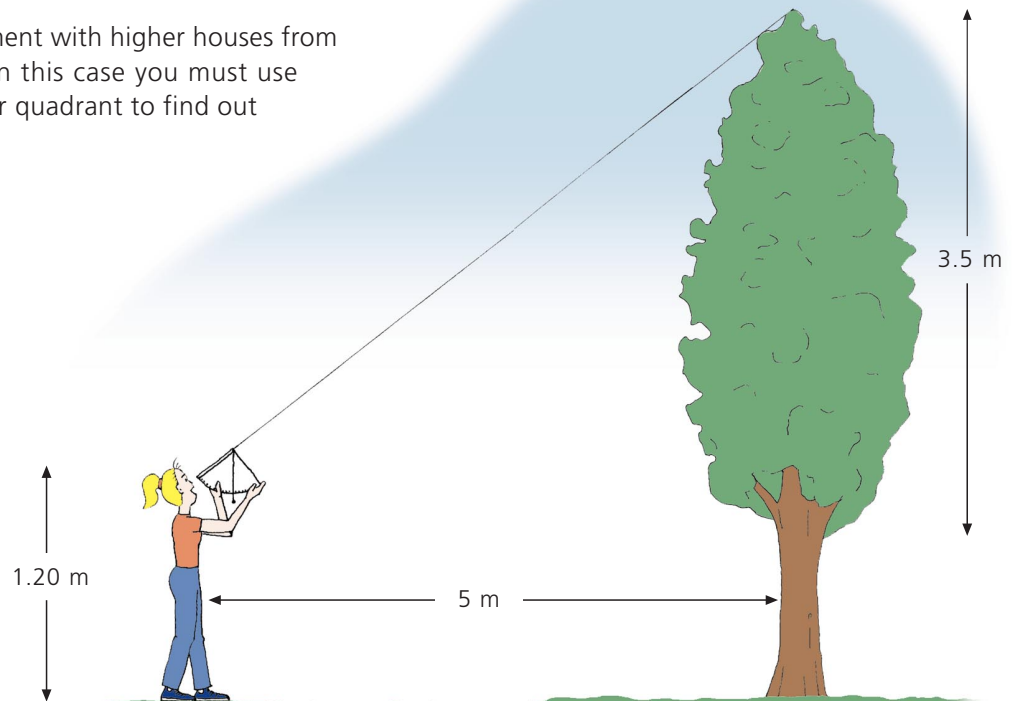

The North Star and latitude

Observation

- Far from the bright lights of the city, in the countryside at night, find north on your compass and then turn towards the north. Stretch out your arm so that it makes an approximate 45° angle with the ground. Now if you look at the sky under your hand, you will see the Little Dipper constellation. The last star in the Little Dipper's tail is called the North Star because it always shows us which direction north is in. If you have come out of a bright place, wait ten minutes for your eyes to become accustomed to the dark. At the end of these ten minutes, you will be able to make out more stars in the sky.
- Ask someone to show you the North Star and the Little Dipper.

From now on, you will always be able to tell which direction is north at night, even without a compass.



Experiment

- Look for the North Star on a starry night. Don't forget that it is found in the north. If you can't find it, ask someone to help you. After you find it, point the straw on your quadrant towards the North Star, look up through the straw and line it up with the North Star. Read the angle that the thread shows on your quadrant scale.
- The angle that you have just taken tells you your position on Earth and is called the latitude of your location. Write this latitude down so that you don't forget it.

Latitude of my location: _____

- The angle of latitude of your location is roughly equal to the angle of the straw on your sundial above the horizon. Use your protractor to measure the incline of the straw on your sundial.

Latitude and longitude

- The lines of the Equator - zero latitude - and the parallels are shown on the globe. The parallels are circumference lines which run parallel to the circumference line of the Equator. Points of the globe along the same parallel have the same latitude.

Latitude is measured from the Equator so all points between the Equator and the North Pole are latitude north and all points between the Equator and the South Pole are latitude south.

- The angle of the North Star above the horizon is the latitude of your location.

Draw your latitude line on your globe.

15th and 16th century Portuguese navigators used the quadrant to find out their position on Earth. Every night, they measured the angle of the North Star above the horizon and noted their position on the globe they carried with them.

In this way, they never got lost on the seas and lands which had never been visited by other Europeans.

- You have learnt to determine latitude on your globe. Similarly, you can draw imaginary circles around the globe which pass through the North Pole and the South Pole. These circles which pass through both poles are called the Earth's meridians.

The longitude of a position is the number of degrees between the Greenwich Meridian and this location, which can be either to the east or to the west.

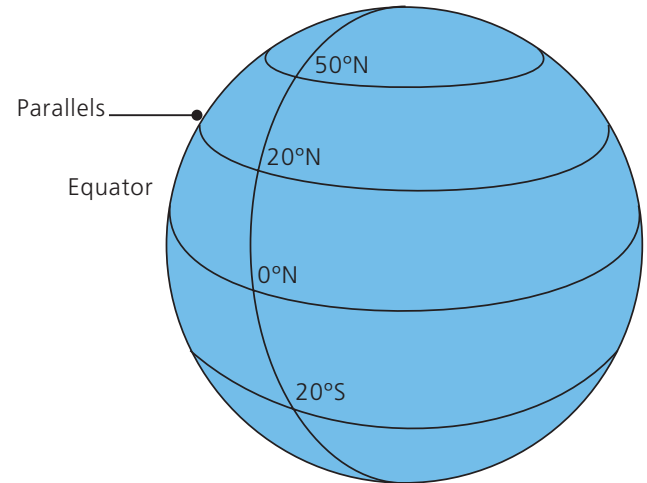

E.g. When you see the North Star from any point along the 20°N line of latitude, the angle of the North Star above the horizon is 20°.

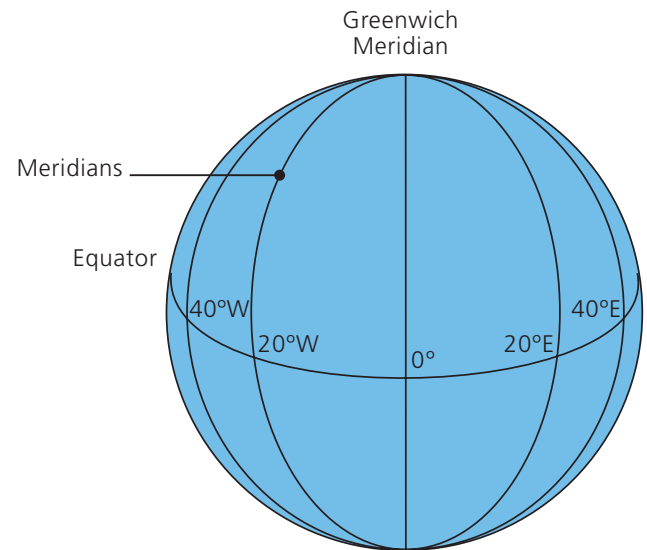

The longitudinal scale is marked along the line of the Equator!

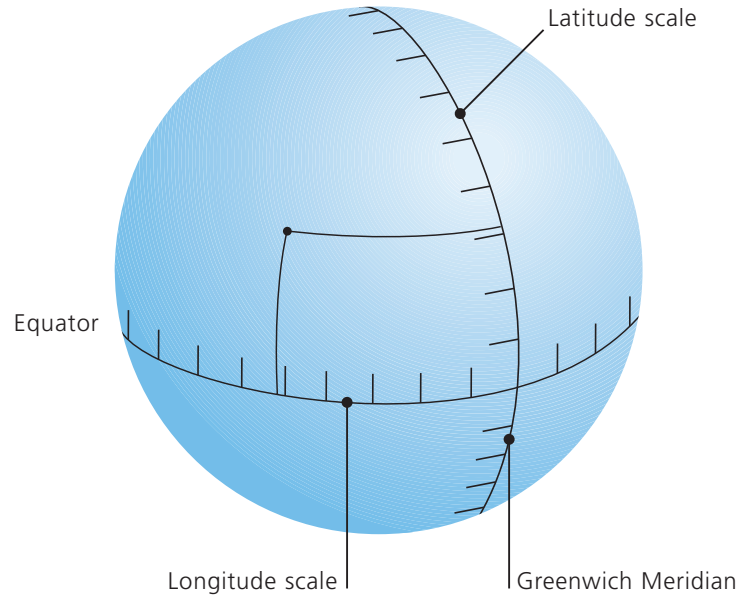
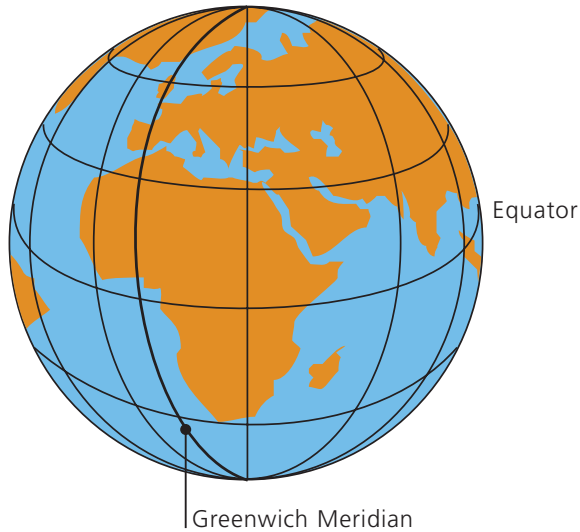

Determining the latitude and longitude of a location.

Activity

On your globe you can see one scale along the line of the Equator and another along the Greenwich Meridian. These scales are the same as the scales on your protractor.

- Choose and mark a Portuguese city on your globe. See if its longitude is east or west of the Greenwich meridian. To determine the latitude and longitude of a location on Earth, you just follow the parallel and the meridian which pass through this city and look at the values on the scales drawn along the Equator and the Greenwich Meridian. Latitude and longitude figures are the degrees travelled from the Equator and the Greenwich Meridian to the point you have chosen.
- Find the place where you live on the globe. Draw a meridian line from your location to the Equator and a parallel line from your location to the Greenwich Meridian. By reading the values on the two scales, you will find out the latitude and longitude of your location.

Latitude: _____ **Longitude:** _____

Now if you compare this latitude with the angle of the North Star above the horizon, you will see that the two figures are almost exactly the same!

The nocturnal

It is impossible to tell the time from a sundial at night.

Using the nocturnal, navigators looked at the North Star and were able to tell the time. They could only do this at night. During the day they used the sundial.

When you look at the night sky, the North Star always shows the north of the Earth. The other stars all revolve around the North Star.

Experiment

Make your own nocturnal.

- Cut out the two wheels and the pointer with a scissors.
- Make a hole through the black dots on the wheels and the pointer.
- Put the two wheels and the pointer together, line up the holes and push a small straw through the hole.

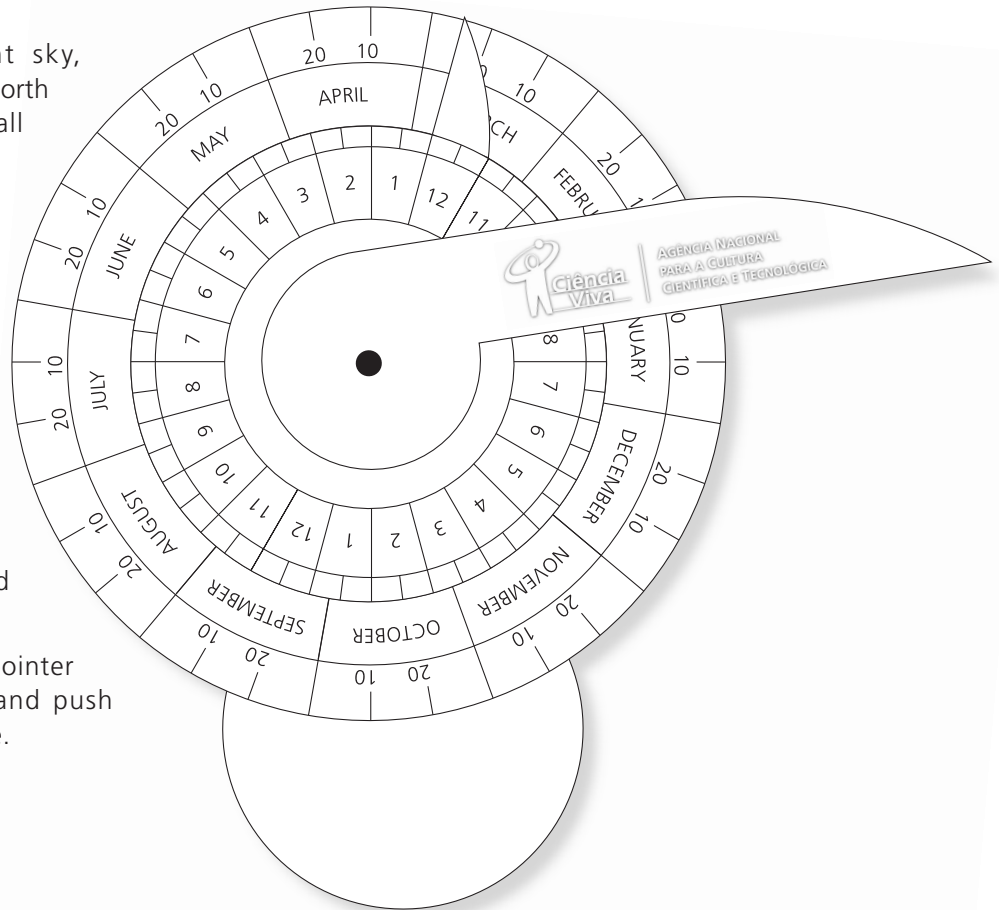

Your nocturnal should look like this

Now you can try out your nocturnal.

Experiment

- Turn the small wheel so that the pointer shows today's date, e.g. if it is the 26th March, the pointer should be in the position shown in the picture.

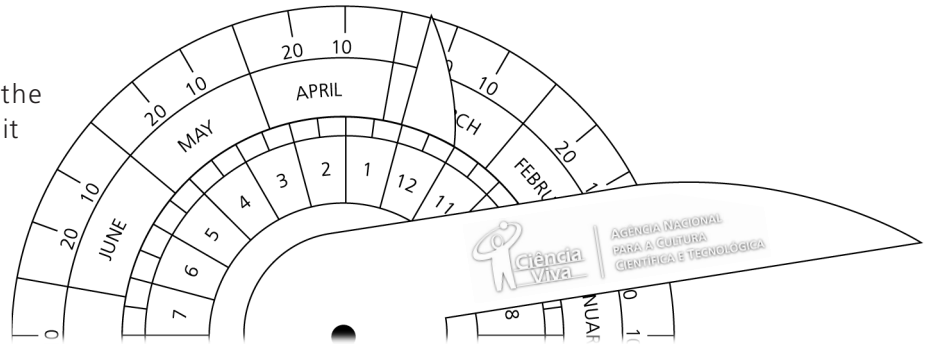

- Take the nocturnal and point it towards the Little Dipper so that you can see the North Star through the hole. Always keep the handle pointing downwards.
- Turn the large pointer until you can see the Kochab Star. Look at the time shown by the small wheel of the nocturnal.

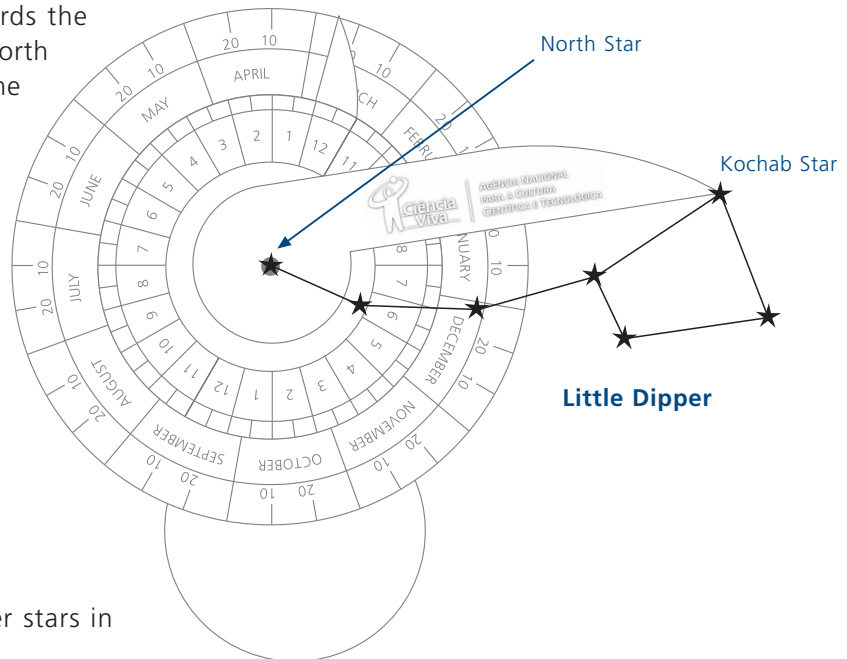

At night, the Little Dipper and the other stars in the sky all revolve around the North Star.



- 1.** Do you live in the Earth's Northern or Southern Hemisphere?
- 2.** What are the cardinal points of the compass?
- 3.** In which directions are north, south, sunrise (east) and sunset (west) where you live?
- 4.** At what time of the day is the shadow of the straw on your sundial at its shortest?
- 5.** How high is your house?
- 6.** What is the latitude and longitude of your area?
- 7.** According to the Kochab star, at what time do you go to bed?
- 8.** Draw a map of the area you live in with a compass rose showing the direction of the North Pole.
- 9.** Find the Tropics of Cancer and Capricorn and the Arctic and Antarctic Circle on your globe.

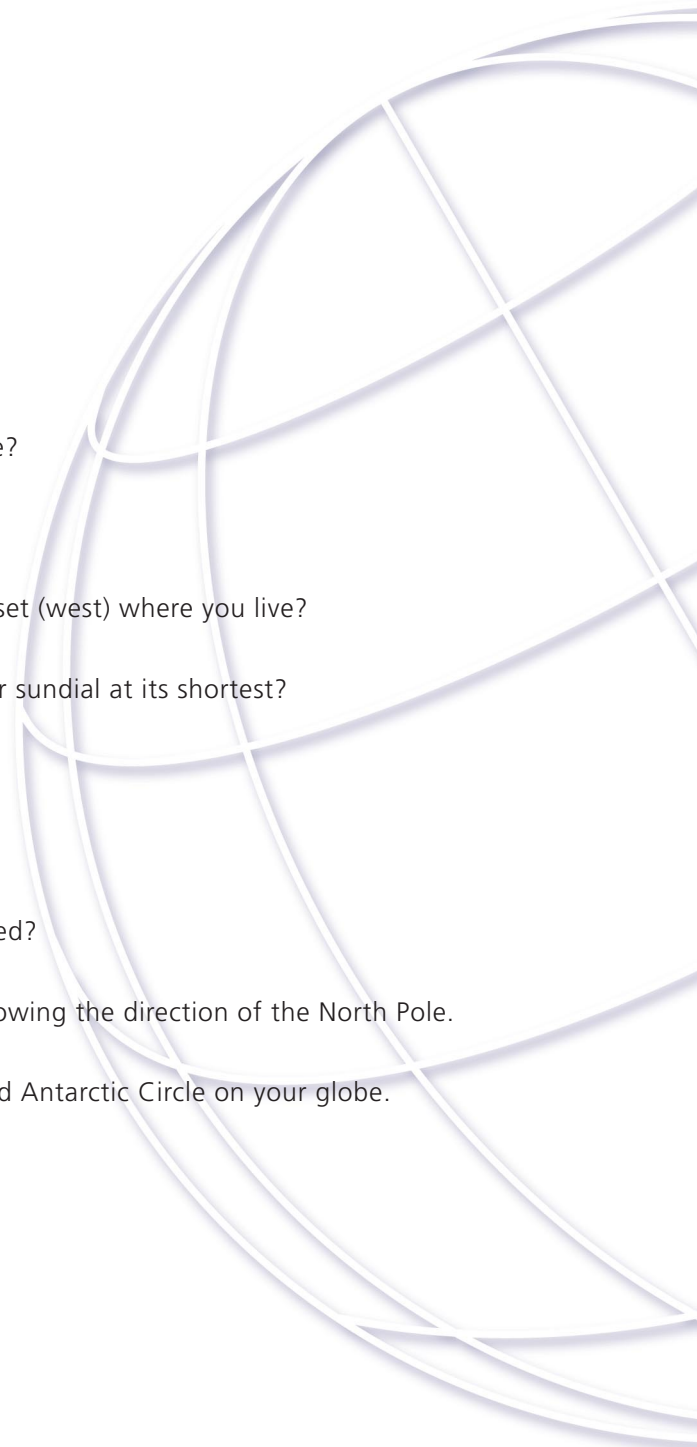

Ciência Viva

Agência Nacional para a Cultura
Científica e Tecnológica

Av. dos Combatentes, 43 A - 10ºA
1600-042 Lisboa · PORTUGAL

Tel.: (351) 21 727 02 28

Fax.: (351) 21 722 02 65

info@cienciaviva.pt

www.cienciaviva.pt

